

Machine ID

10141654/10

Date

31/10/17, 8:46 am

Company

Marley flow control

Operator

Simon Jones

Notes

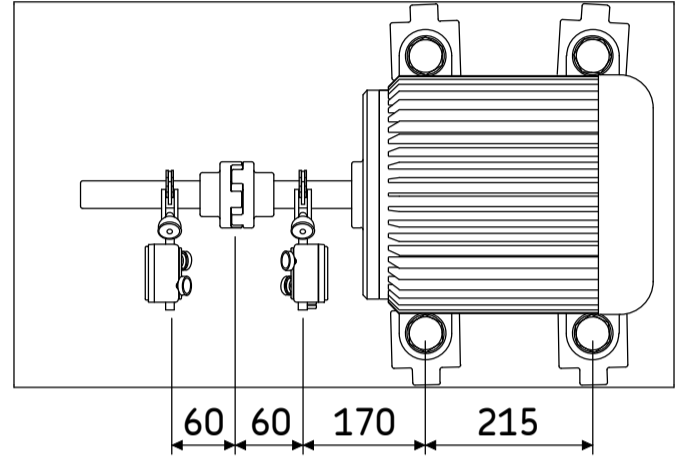

Tolerances

Speed (rpm)	Offset (mm)	Angular Error (mm/100)
Custom	0.25	0.25

Target Values

	Vertical	Horizontal
Offset (mm)	-	-
Angle (mm/100)	-	-

Stationary Unit (S): TKSA 51, 1707-0080

Movable Unit (M): TKSA 51, 1711-0017

Soft Foot Check Performed: No

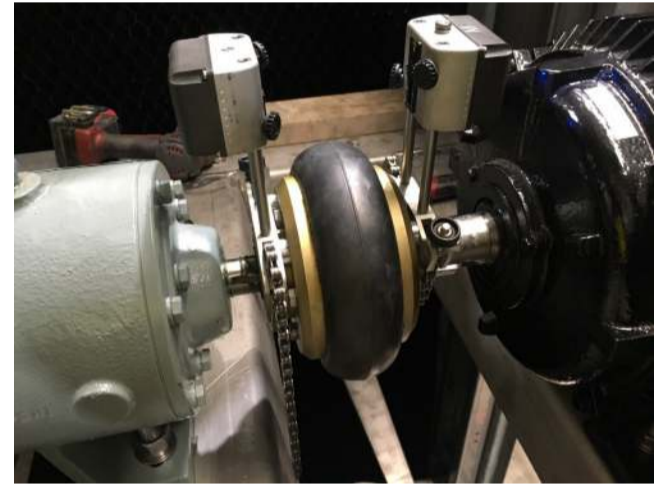

Result

As Found	Vertical	Horizontal
Offset (mm)	-0.36	-0.33
Angle (mm/100)	-0.19	0.00
Front Feet (mm)	-0.78	-0.33
Rear Feet (mm)	-1.19	-0.33

As Corrected	Vertical	Horizontal
Offset (mm)	-0.03	0.05
Angle (mm/100)	-0.03	-0.16
Front Feet (mm)	-0.10	-0.32
Rear Feet (mm)	-0.17	-0.67

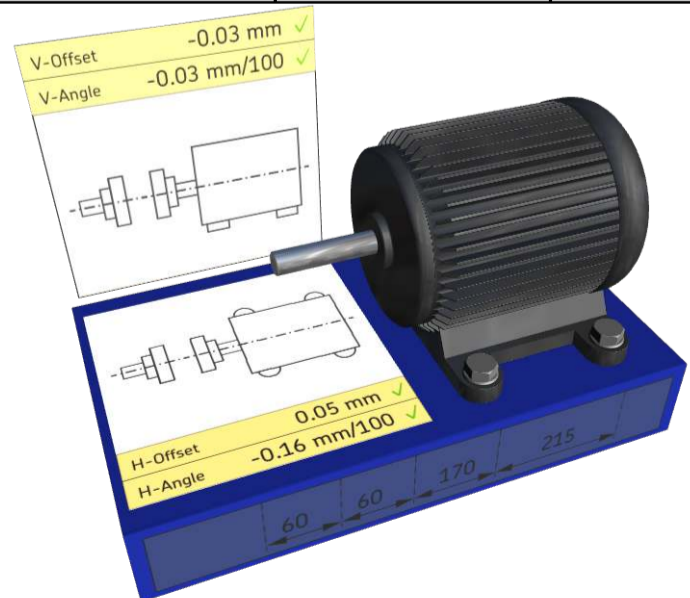
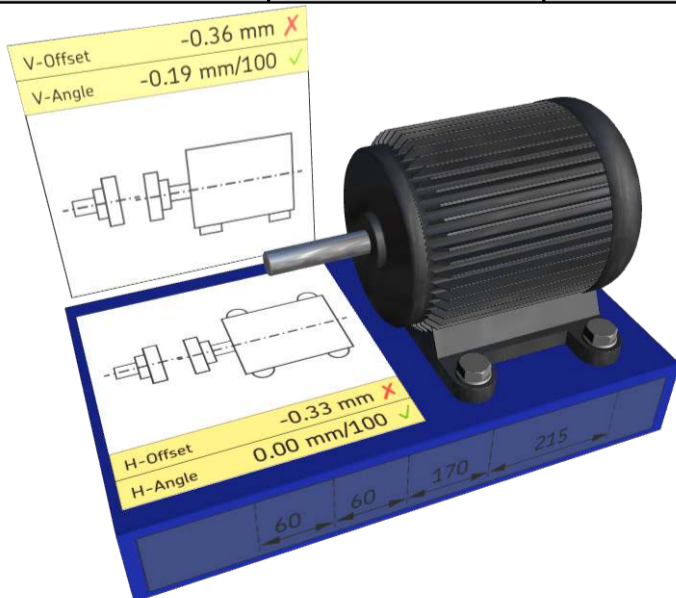

Signature 31/10/17